

FRONT VIEW

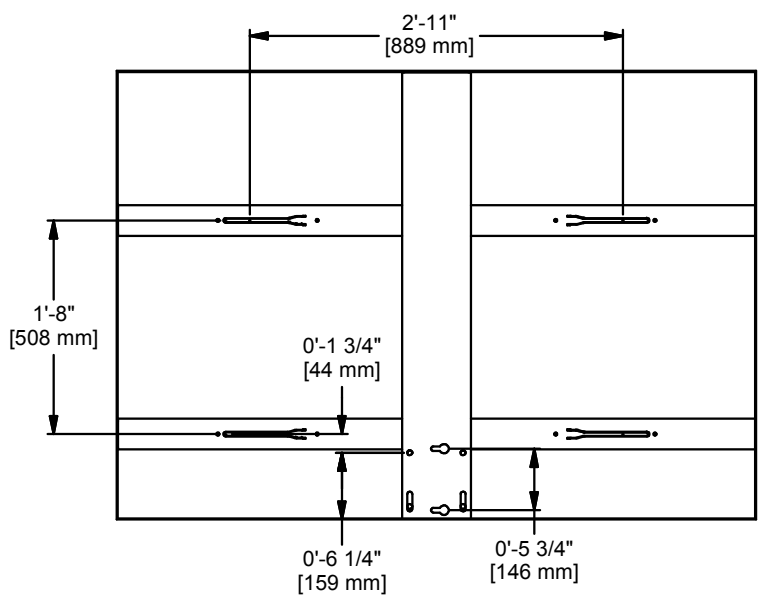

REAR VIEW

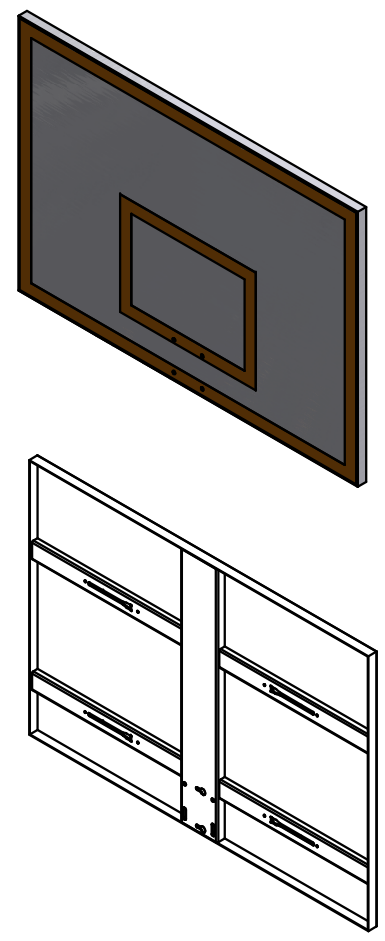

12 GA. STEEL STAMPED SHELL WITH 12 GA. FORMED HORIZONTAL MOUNTING CHANNELS AND A 10 GA. FORMED VERTICAL CHANNEL WELDED TO REVERSE SIDE.

BOARD IS POWDER COATED WHITE WITH ORANGE TARGET AND BORDER.

B	WDC	07-26-19
REV	BY	DATE

PSS
PERFORMANCE
SPORTS SYSTEMS

G
GARED™

Gared Holdings, LLC
9200 E. 146th St. Noblesville, IN 46060

THIS DOCUMENT CONTAINS TRADE SECRET AND OTHER MATERIALS WHICH ARE PROTECTED BY CONFIDENTIALITY NOTICE AND AGREEMENT AND BY COPYRIGHT. ANY USE OR COPYING OF THIS DOCUMENT EXCEPT AS AUTHORIZED BY GARED HOLDINGS, LLC IS STRICTLY PROHIBITED.

42"x60" RECT. STEEL BACKBOARD W/ BORDER

DRAWN	CROSBY	DATE	7/26/2019	DATE ISSUED
APPROVED		DATE		

FILE LOC: Q:\Inventor Files\Specification Files\07_Backboards

SIZE	SCALE	SHT. NO.	PART NO.	REV
A		1 OF 2	1260B	B



1260B

60" X 42" RECTANGULAR STEEL BACKBOARD WITH BORDER AND TARGET

The 1260B backboard shall be formed from a single piece of heavy gauge steel and reinforced with a heavy gauge vertical center channel and heavy gauge horizontal channels. All reinforcing sections shall be welded to the shell to make a single vibration free unit. Manufacturer of backboard shall have over ten years of experience producing such item.

Key-slots in the horizontal channels shall be spaced at 20" vertical and 35" horizontal. Backboard shall be phosphate pre-treated and shall have a durable white powder coat finish to protect against weathering. Orange border and target shall be silk-screened on face of backboard for permanent markings. Goal mounting holes shall be on 5" horizontal and 5" vertical centers.

ACCESSORIES

GOALS

See Goal-Board Matrix specification sheet for goal compatibility.

Subject to design change and current manufacturing practices.