

FRONT VIEW

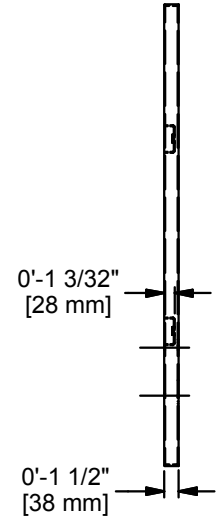

SIDE VIEW

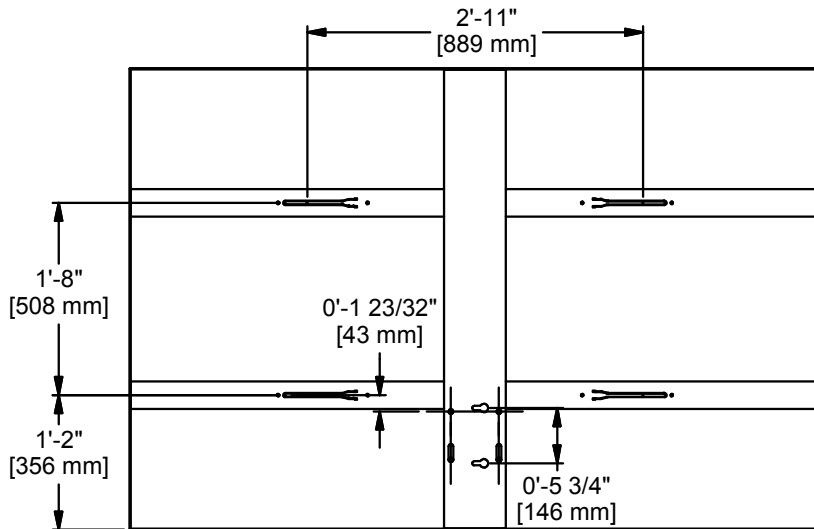

REAR VIEW

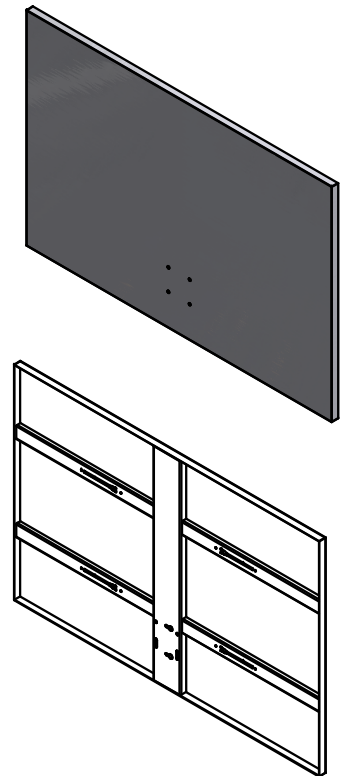

12 GA. STEEL STAMPED SHELL WITH 12 GA. FORMED MOUNTING AND STIFFENING CHANNELS WELDED TO REVERSE SIDE.

MOUNTING HOLES FOR 3/8" DIAMETER GOAL AND BOARD MOUNTING HARDWARE.

BOARD IS POWDER COATED GLOSS WHITE.



Gared Holdings, LLC
9200 E. 146th St. Noblesville, IN 46060

THIS DOCUMENT CONTAINS TRADE SECRET AND OTHER MATERIALS WHICH ARE PROTECTED BY CONFIDENTIALITY NOTICE AND AGREEMENT AND BY COPYRIGHT. ANY USE OR COPYING OF THIS DOCUMENT EXCEPT AS AUTHORIZED BY GARED HOLDINGS, LLC IS STRICTLY PROHIBITED.

48" X 72" RECT. STEEL BACKBOARD

DRAWN	CROSBY	DATE	7/29/2019	DATE ISSUED
APPROVED		DATE		

FILE LOC. Q:\Inventor Files\Specification Files\07_Backboards

SIZE	SCALE	SHT. NO.	PART NO.	REV
A	NONE	1 OF 2	1270	B

B	WDC	07-29-19
REV	BY	DATE



MODEL 1270

72" X 48" RECTANGULAR STEEL BACKBOARD

The 1270 backboard shall be formed from a single piece of heavy gauge steel and reinforced with a heavy gauge vertical center channel and heavy gauge horizontal channels. All reinforcing sections shall be welded to the shell to make a single vibration free unit. Manufacturer of backboard shall have over ten years experience producing such item.

Key-slots in the horizontal channels shall be spaced at 20" vertical and 35" horizontal. Backboard shall be phosphate pre-treated and shall have a durable white powder coat finish to protect against weathering. Goal mounting holes shall be on 5" horizontal and 5" vertical centers.

ACCESSORIES

GOALS

See Goal-Board Matrix specification sheet for goal compatibility.

Subject to design change and current manufacturing practices.